



VAULT RESTROOM BUILDING EXAMPLE



PICNIC SHELTER IMAGERY

IMPERVIOUS CALCULATION		
	PHASE ONE	PHASE TWO
EXISTING IMPERVIOUS	53,075 SF	16,412 SF
PROPOSED IMPERVIOUS	42,490 SF	19,624 SF
NET CHANGES IN IMPERVIOUS	-10,285 SF	3,212 SF

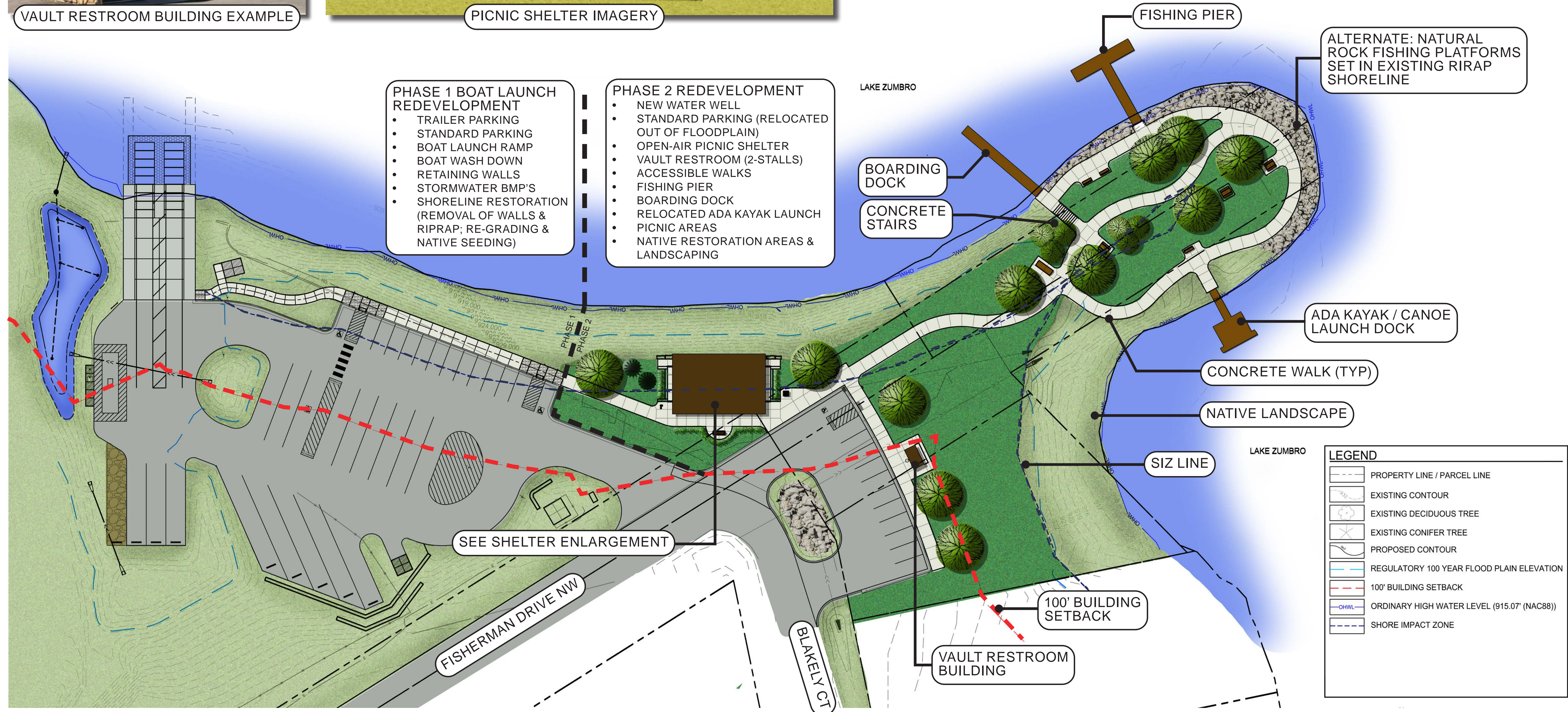

# Lake Zumbro Park Phase 2 | Overall Site Plan

Oronoco, Minnesota  
2026 | WSB Project number: 031052-000

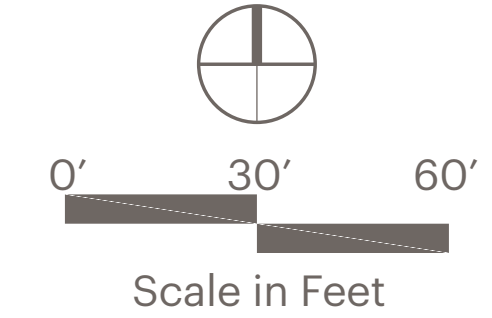

C:\ACCA\CCDOCS\WSB\031052-000\Project Files\05\_Discipline\Permitting\Phase 2 Permits\Exhibits\031052-000-Lake Zumbro Site Plan\_2026-0501

C:\ACCA\CCDOCS\WSB\031052-000\Project Files\05\_Discipline\Permitting\Phase 2 Permits\Exhibits\031052-000-Lake Zumbro Site Plan\_2026-0501

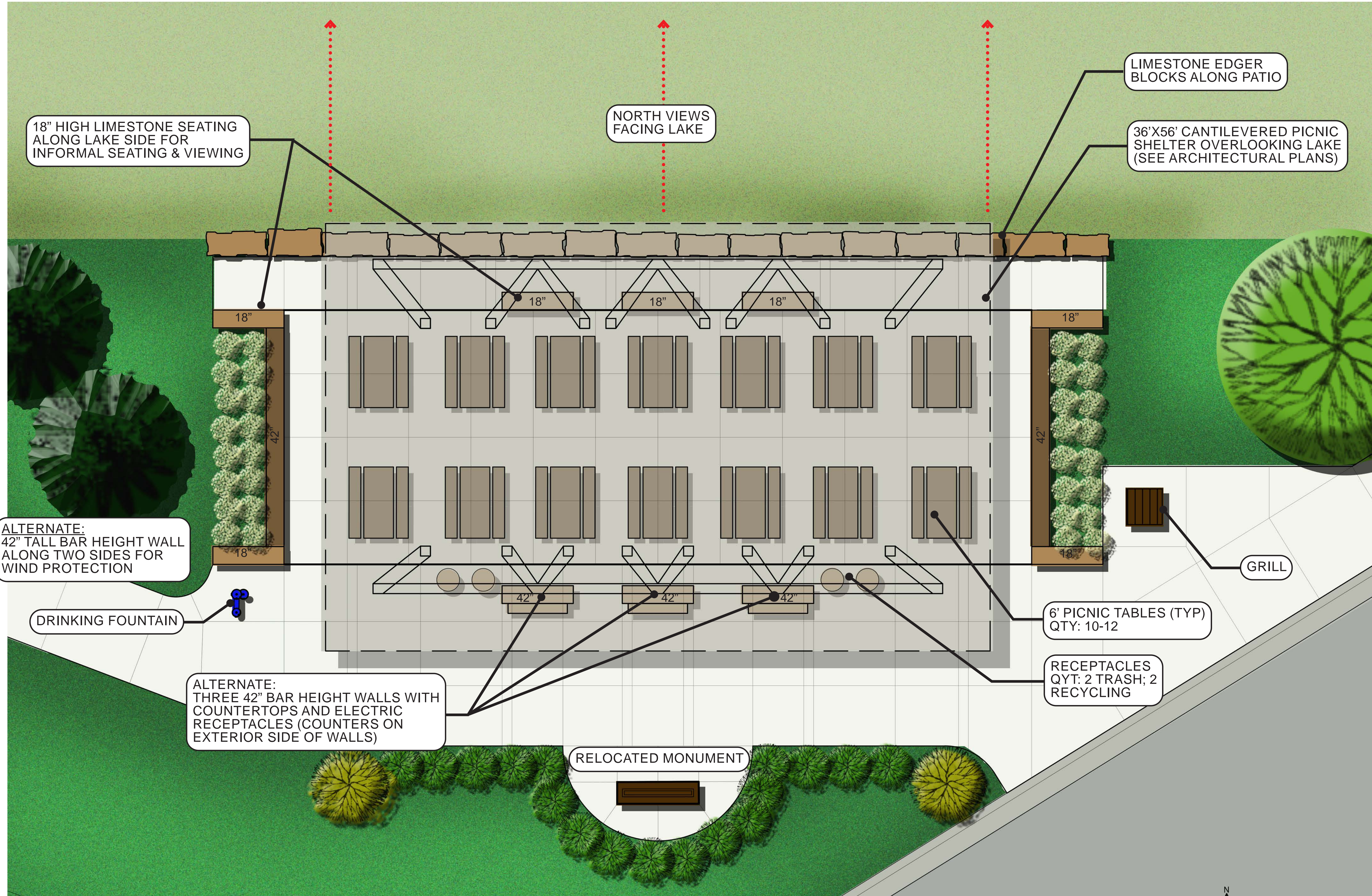

# Lake Zumbro Park Phase 2 | Picnic Shelter Enlargement Plan

Oronoco, Minnesota  
2026 | WSB Project number: 031052-000

